

Overhead-Line Winches Type KW 3F – KW 4F



Overhead line construction demands a maximum of reliability and operating precision of the winches used. To remove the fixing clamps of the insulators, the cable has to be lifted exactly to a point where the insulators are relieved from the cable load, but at the same time are no longer pressed against the fittings. Until the insulators are disconnected, the cable has to be lowered at a precisely controlled rate. This requires precise control and freedom of jerks. Any jerk of the cable may endanger the safety and life of the men high up in the pylon.



Winch KW 3F at dismantling job on a 110 kV overhead-line

Function:

Thanks to the automatic hold-on (static pull) system, the overhead cable can be held in any desired position by means of the pulling force preselector. At the point where the insulator can be freely moved, the hydraulically controlled multiple disk brake is put on. As soon as the insulators are removed, the winch is put in reverse and starts running against the hydraulic load brake. Balancing the pressure of the hydraulic pump and the action of the load brake precisely controls the cable-lowering rate.

The overhead line winch of Type KW 3F is equipped with a electronic printer and may also be used for pulling underground cables without the need for any refitting.

Specifications are subject without notice. Output details are depending on use conditions.

Overhead-Line Winches

Type KW 3F – KW 4F



Standard design:

- Chassis with overrunning and automatic reversing brake system, height adjustable tow-bar with ring-eye and ball type coupling, 12 V lighting system and TÜV-approval
- Lockable, soundproof sheet metal hood
- PC 210 pulling force control and recording device
- Working hour counter
- Diesel engine with hydrostatic gear system
- Twin capstan system with rope storage drum and 500 m rope
- Multiple disk brake
- Painting: traffic red RAL 3020

Extras: (on request)

- other types of engines, painting or rope lengths
- Telescopic deflection boom

Due to special equipments dimensions and weights may differ.

Technical Data:

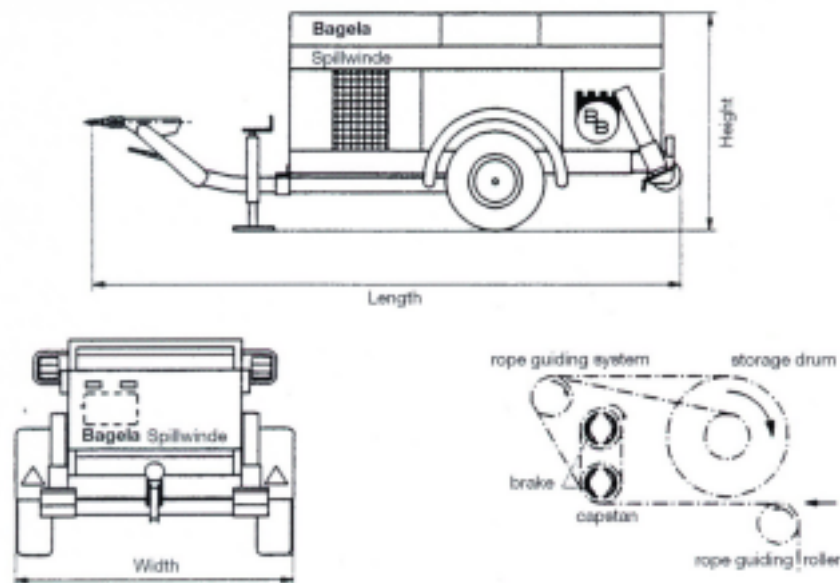

-o single-straight

-o single-height-adj.

-oo tandem-straight

-oo tandem-height-adj.

Type	Max. pulling		Drive engine			Rope-		Chassis		Length	Width	Height	Weight	Lift-load	Order No.
	force	speed	kW	fuel	cyl.	dia.	length	type	brake						
KW 3F	30 kN	50 m/min	15	diesel	3 W	10 mm	500 m	-o 1,6	overrun- ning	4000 mm	1650 mm	1300 mm	1400 kg	1,5 t	001.713.59
KW 4F	40 kN	50 m/min	15	diesel	3 W	11 mm	500 m	-o 1,6	overrun- ning	4000 mm	1650 mm	1300 mm	1500 kg	2,0 t	001.713.79

Specifications are subject without notice. Output details are depending on use conditions.