

# Cable Pulling Winches With Automatic Hold-On Pull-System Type RKW 3 – RKW 4 – RKW 5 30 – 50 kN

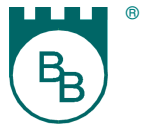

A normal cable pulling winch is stopped by the pulling force control and recording device with adjustable pull limiting switch as soon as the preselected pulling force is reached. The winches of this series (RKW) are of a dual-purpose type designed for pipe renewal and cable pulling. They include an additional hydraulic device:

## **Pulling force preselection with automatic hold-on pull (static pull) system.**



If the pipe or cable pulled gets stuck along its course, the winch will continue its pull until the preselected pulling force is reached and will then keep pulling at zero rate (static pull) until the resistance has been overcome by manual assistance, use of cable pushers etc., after which the winch will go on pulling normally. This additional feature of Bagela winches of the RKW series contributes to versatility of application and makes them ideal for all kinds of pipe renewal jobs.

The PC 210 a pulling force control and recording device with adjustable pull limiting switch indicates the following values: pulling force, pulling speed and pulled-in length. A separate printer enables a print on normal paper rolls directly on the building site.

Specifications are subject to change without notice. Output details are depending on use conditions.

# Cable Pulling Winches With Automatic Hold-On Pull-System

## Type RKW 3 – RKW 4 – RKW 5 30 – 50 kN



### Standard design:

- Chassis with overrunning and automatic reversing brake system, height adjustable tow-bar with ring-eye and ball type coupling, 12 V lighting system and TÜV-approval
- Lockable, soundproof sheet metal hood
- PC 210 pulling force control and recording device with adjustable pull limiting switch
- Electronic meter counter
- Operating hour counter
- Diesel engine with hydrostatic gear system
- Pulling force preselection with automatic pre-tension system
- Twin capstan system with rope storage drum and 500 m rope
- Painting: traffic red RAL 3020

### Extras: (on request)

- other types of engines, painting or rope lengths
- Telescopic deflection boom

**Dimensions and weights may differ if extras are fitted.**

### Technical Data:

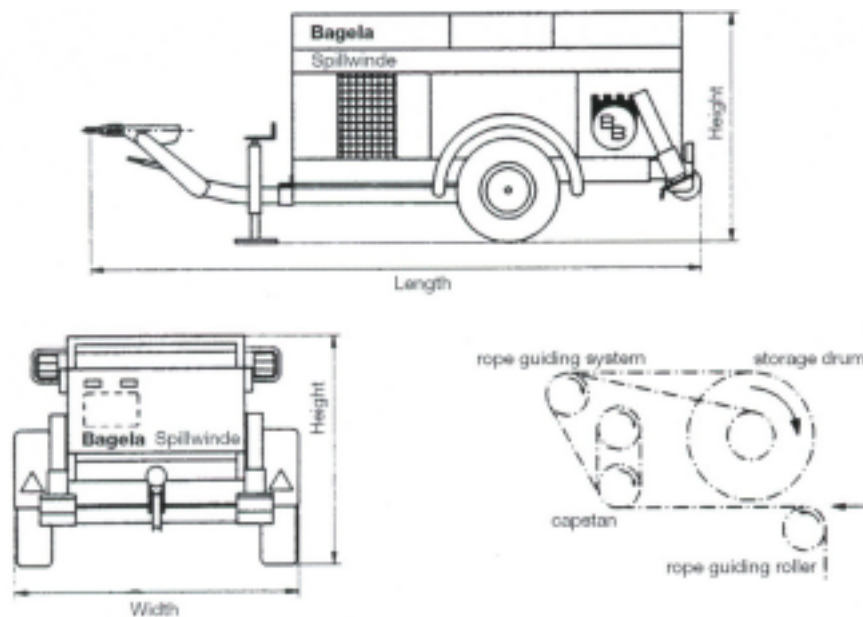

-o single-straight

-o single-height-adj.

-oo tandem-straight

-oo tandem-height-adj.

Type	Max. pulling		Drive engine			Rope-		Chassis		Length	Width	Height	Weight	Order No.
	force	speed	kW	fuel	cyl.	dia.	length	type	brake					
<b>RKW 3</b>	30 kN	40 m/min	20	diesel	4 W	10 mm	500 m	-o 1,6	over- running	4200 mm	1650 mm	1300 mm	1400 kg	<b>001.268.10</b>
<b>RKW 4</b>	40 kN	40 m/min	20	diesel	4 W	11 mm	500 m	-oo 2,0	over- running	4200 mm	1600 mm	1250 mm	1500 kg	<b>001.268.25</b>
<b>RKW 5</b>	50 kN	30 m/min	20	diesel	4 W	12 mm	500 m	-oo 2,0	over- running	4200 mm	1600 mm	1250 mm	1650 kg	<b>001.269.02</b>

Specifications are subject to change without notice. Output details are depending on use conditions.